



# Twin City Fan & Blower

INSTALLATION, OPERATION & MAINTENANCE MANUAL

## Centrifugal Square Inline Fans

# IM 4205

Issue Date: 6-04  
Rev. Date: 12-09

Twin City Fan & Blower Bulletin 4205 provides additional information on this equipment. This bulletin can be found at [www.tcf.com](http://www.tcf.com) or by contacting your local Twin City Fan & Blower sales representative.



**Models BSI - 080A through 402A**

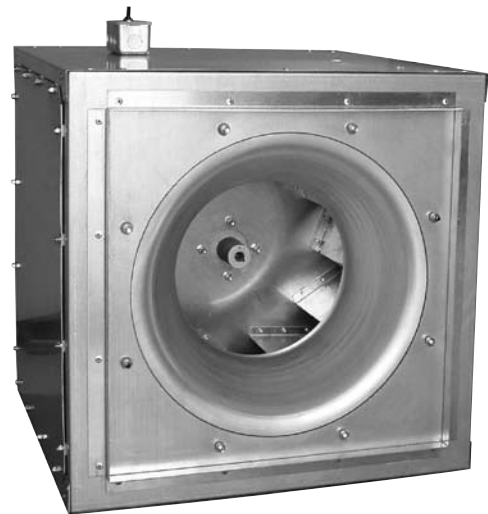

**Models DSI - 080A through 165A**

### Nomenclature

BSI = Belt Driven Centrifugal Inline  
DSI = Direct Drive Centrifugal Inline

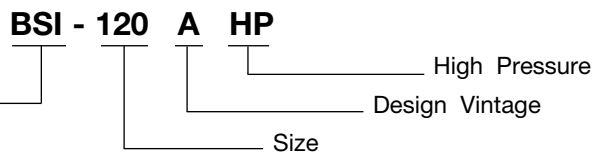

## Receiving, Inspection, & Unpacking

When the equipment is received all items should be carefully checked against the bill of lading to be sure all crates and cartons have been received. Before accepting delivery, carefully inspect each carton or crate for visible shipping damage. If any damage is noticed, the carrier should make the proper notation on the delivery receipt acknowledging the damage. Make notations of all damage on all copies of the bill of lading and have all copies countersigned by the delivering carrier. The carrier should also fill out a Carrier Inspection Report. The factory Traffic Department should then be contacted. File claim for damage with the carrier. Physical damage to the unit after acceptance is not the responsibility of Twin City Fan Companies, Ltd.

Unpack each carton or crate and verify that all required parts and proper quantities of each item have been received. Refer to drawings for part descriptions. Report shortages or missing items to your local representative to arrange for replacement parts.

Due to availability of carriers and truck space, it is not possible to guarantee that all items will be shipped together. Verification of shipments must be limited to only those items on the bill of lading.

**The unit nameplate must be checked to make sure the voltage agrees with the power supply available.**

## General Installation

**CAUTION: Sheet metal parts, screws, clips and similar items inherently have sharp edges, and it is necessary that the installer and service personnel exercise caution.**

The installation of this equipment shall be in accordance with the regulations of authorities having jurisdiction and with all applicable codes.

This equipment is to be installed by an experienced installation company and fully trained personnel.

The mechanical installation of the inline centrifugal fan consists of making final connections between the unit, building services, and duct connections.

## Electrical Connection

1. Connect supply wiring to the disconnect switch (non-fused standard). Check the wiring diagrams on the motor for connections.
2. The motor is factory set at the voltage marked on the fan nameplate. Check the line voltage with the nameplate voltage and wiring diagrams.
3. The main power wiring should be sized for the ampacity shown on the dataplate. Size wires in accordance with the ampacity tables in Article 310 of the National Electrical Code. If long wires are required, it may be necessary to increase wire size to prevent excessive voltage drop. Wires should be sized for a maximum of 3% voltage drop.

**CAUTION:** Use copper conductors only.

**CAUTION:** Protect wiring from sharp edges. Leave some slack in the line to prevent damage.

4. Disconnect switches are not fused. The power leads must be protected at the point of distribution in accordance with the fan dataplate.

5. On fans without a thermal protector integral to the motor (refer to unit or motor dataplate to determine if protector is present) a separate overload device is required. Refer to Sections 430-32 of the N.E.C. for sizing.

6. All units must be electrically grounded in accordance with local codes or, in the absence of local codes, with the latest edition of the National Electrical Code (ANSI/NFPA 70). A ground lug is provided as standard in the unit terminal box. Size grounding conductor in accordance with Table 250-95 of the National Electrical Code. **DO NOT** use the ground lug for connecting a neutral conductor.

7. Supply voltage to the inline fan should not vary by more than 10% of the value indicated on the unit dataplate. Phase unbalance must not exceed 2%.

**WARNING:** Failure of motor due to operation on improper line voltage or with excessive phase unbalance constitutes product abuse and may cause severe damage to the unit's electrical components.

# Check, Test & Start Procedure

## WARNING

Electric shock hazard. Could cause severe injury or death. Failure to bond the frame of this equipment to the building electrical ground by use of the grounding terminal provided or other acceptable means may result in electrical shock. Disconnect electric power before servicing equipment. Service to be performed only by qualified personnel.

### BEFORE START-UP: Disconnect power to this unit before servicing the unit.

1. Check to verify that the wheel is free to rotate.
2. For optimum fan performance make sure that the wheel to inlet venturi overlap is maintained. See Table 1.
3. Verify that supply voltage on the line side of disconnect agrees with voltage on fan data plate and is within the 10% utilization voltage.
4. Apply power to unit and check rotation of wheel with the directional arrow on the unit. See Table 2.

**WARNING:** Rotation is critical. If allowed to operate in the wrong direction, the motor will overload and burn out.

**WARNING:** Check units for rotation. For three-phase, rotation can be changed by interchanging any two of the three line leads. If unit is checked on temporary wiring, it should be rechecked when permanently installed. Motor burn-out or tripped overload protection devices are usually the result of wrong rotation.

5. **Electrical Input Check:** Perform check of fan ampere draw and verify that motor nameplate amps are not exceeded. Take into account the service factor range if motor is nameplated above a 1.0 service factor.
6. Fan RPM should be checked and verified with a tachometer.
7. **Units with Speed Control (Direct Drive):** Verify that speed controller gives desired operating range of RPM. If minimum speed value is not desired, it may be adjusted. See page 4.

**NOTE:** The fan was balanced at the factory to be within stringent vibration levels before shipment. However, there are several things that may cause vibration, such as rough handling in shipment and installation, weak foundations and alignments.

Table 1. Wheel to Inlet Venturi

MODEL	OVERLAP
BSI	0.50
DSI	0.50

Table 2. Wheel Rotation\*

MODEL	CW	CCW
BSI	all	---
DSI	---	all

\* Wheel rotation is determined when viewed from discharge.  
**Note:** On fans with three phase motors the wheel rotation can be changed by reversing any two power leads.

Figure 1. Fan Wheel Rotation - View from Discharge

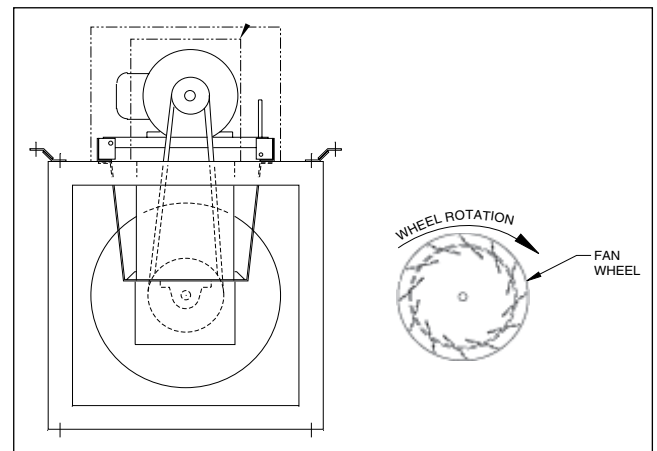

**Note:** CW rotation shown, CCW rotation is similar but opposite.

# Speed Control Installation

(Model DSI - optional)

Speed control is available for DSI models using **115/60/1 open** type PSC or shaded pole motors.

## Installation

Connect control in series with motor and line voltage (**115V only**). Never connect across line. See Figure 2.

## Minimum Speed Setpoint

All controls are factory set to 65V±3V output as standard with an input voltage of 120V. If different minimum speed is desired, the control may be adjusted by turning minimum speed pot clockwise to decrease minimum speed and counterclockwise to increase minimum speed. Refer to Figure 3.

**Warning:** If minimum speed is readjusted, verify unit ampere draw does not exceed motor nameplate amps. Do not operate unit in range where amp draw exceeds motor nameplate.

**Caution:** These motors operate more efficiently in the ranges set from the factory. Operating motor outside these ranges (see Table 3) may cause motor to run hotter and substantially shorten motor life.

**Note:** Lowering the minimum speed setpoint may adversely affect motor start-up characteristics.

**Warning:** Certain failure modes of solid-state controls such as half-waving can cause high levels of DC, motor overheating and motor burn-out. Therefore, a thermal overload protection (integral with motor) is required to limit the maximum motor temperature under such a failure.

**Note:** Do not allow any sleeve bearing motor to operate below 500 RPM. Operation below 500 RPM will substantially shorten bearing life.

Figure 2. Connection Diagram, Speed Control

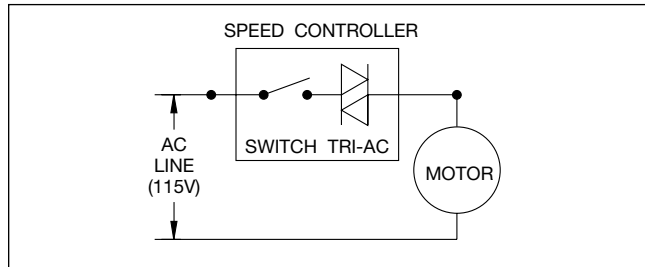

Table 3. Speed Controller RPM Range

HP	RPM	MAX. RPM	MIN. RPM
1/30 1/8	1650/1500/1350 <sup>2,3</sup>	1650 <sup>4</sup> 1500 <sup>5</sup>	1300 <sup>4</sup> 950 <sup>5</sup>
1/15 1/8 1/6 1/4 1/2	860	860	500
1/8 1/6 1/4 1/2	1140	1140	900
1 1/3 1/2 3/4	1725	1725	1200

**NOTES:**

- ① Speed control available **only** with 115/60/1 open motors (thermally protected).
- ② Three-speed motor (multiple tap winding).
- ③ Speed control **should not** be connected to low speed tap on motor because of starting characteristics.
- ④ Speed control connected to high speed tap on motor.
- ⑤ Speed control connected to medium speed tap on motor.

Table 4. Speed Controller Size

MOTOR					SPEED CONTROLLER DESIGNATION / FLA"		
PART NUMBER	ENCLOSURE	VOLT-AGE	HP	RPM	KBWC-15K 5 AMP	KBWC-110 10 AMP	KBWC-115 15 AMP
66801400	Open	115V	1/30	1650/1500/1350	X		
66543600	Open	115V	1/8	1650/1500/1350	X		
66804500	Open	115V	1/15	860	X		
66543700	Open	115V	1/8	860	X		
67123100	Open	115V	1/6	860	X		
66543800	Open	115V	1/4	860	X		
66543900	Open	115V	1/2	860		X	
66804600	Open	115V	1/8	1140	X		
67125100	Open	115V	1/6	1140	X		
66544000	Open	115V	1/4	1140	X		
66544100	Open	115V	1/2	1140		X	
66544200	Open	115V	1	1140			X
66544300	Open	115V	1/3	1725		X	
66544400	Open	115V	1/2	1725		X	
67122500	Open	115V	3/4	1725			X

Figure 3. Low End Setpoint Adjustment

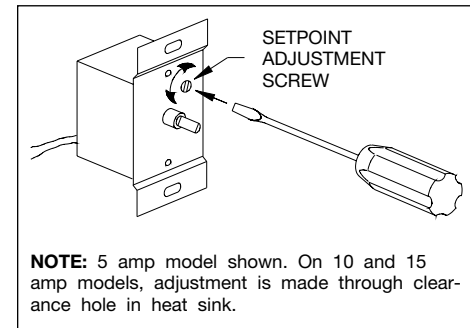

**NOTE:** 5 amp model shown. On 10 and 15 amp models, adjustment is made through clearance hole in heat sink.

## V-Belts (Model BSI)

V-belts on these belt driven fans are oil, heat, and static resistant type and oversized for continuous duty. With proper installation and maintenance, years of operating efficiency can be added to the lifespan of the V-belt drive.

The condition of V-belts and the amount of belt tension should be checked prior to start-up (see Figure 4). When it becomes necessary to adjust belt tension, do not over-tension as bearing damage will occur. Recommended belt tension should permit  $\frac{1}{64}$ " deflection per inch of span of the belt at the center of the belt span. To find this point, measure halfway between the pulley centerlines as shown in Figure 5. Extreme care must be exercised when adjusting V-belts as not to misalign the pulleys. Any misalignment will cause a sharp reduction in belt life and will also produce squeaky, annoying noises (see Figure 6). On units equipped with 2 groove pulleys, adjustments must be made so that there is equal tension on all belts (see Figure 7).

1. Where tensioning rods are not provided, adjustment is more easily obtained by loosening and adjusting one side of the motor bracket at a time.

2. Always loosen tension adjustment enough to place belts on sheaves without running belts over the edge of either sheave. A new belt may be seriously damaged internally by careless handling (see Figure 8).

**WARNING:** When removing or installing belts, never force belts over pulleys without loosening motor first to relieve belt tension.

3. Fan speed can be increased by closing the adjustable motor pulley or decreased by opening it. Always check the load on the motor when increasing the fan speed.

Figure 4. Eliminate Slack

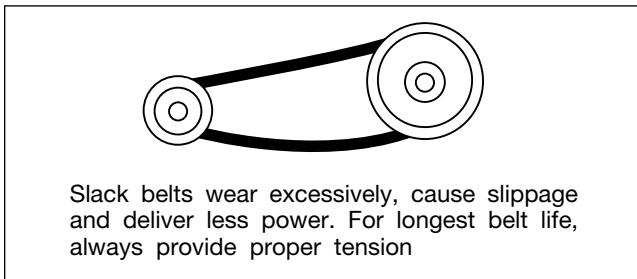

Figure 5. Belt Deflection

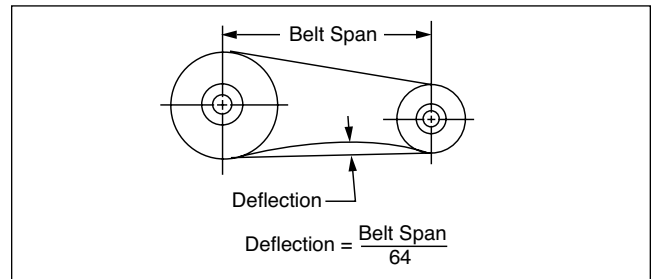

Figure 6. Mounting Belts

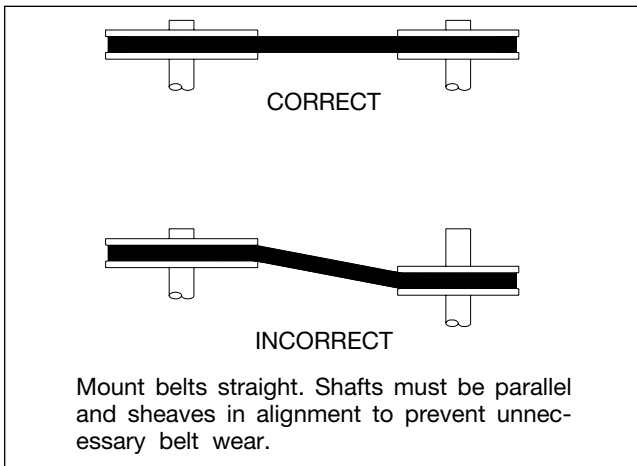

Figure 7. Sheaves

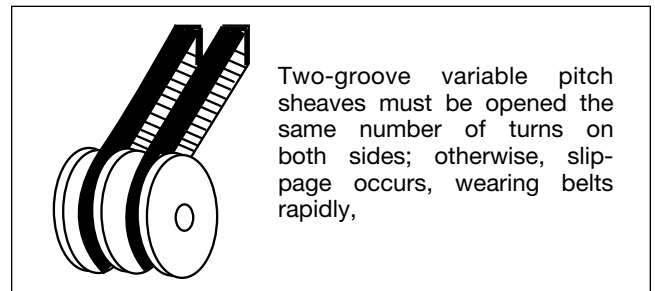
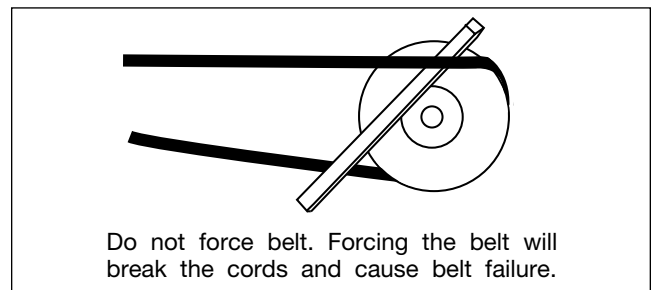

Figure 8. Belts



# Fan Troubleshooting Chart

PROBLEM	POSSIBLE CAUSES
FAN DOES NOT OPERATE	<ol style="list-style-type: none"> <li>1. Wrong voltage.</li> <li>2. Electricity turned off or not wired properly.</li> <li>3. Tripped overload protector.</li> <li>4. Blown fuses.</li> <li>5. Loose pulleys.</li> <li>6. Broken belts.</li> </ol>
TOO LITTLE AIR	<ol style="list-style-type: none"> <li>1. Wheel rotating in wrong direction.</li> <li>2. Fan speed lower than design.</li> <li>3. System is more restrictive (more static pressure) than expected.</li> <li>4. Restricted fan inlet or outlet.</li> <li>5. Inlet or outlet screens clogged.</li> <li>6. Filters (if applicable) are dirty or clogged.</li> </ol>
TOO MUCH AIR	<ol style="list-style-type: none"> <li>1. Fan speed higher than design.</li> <li>2. System is less restrictive (less static pressure) than expected.</li> </ol>
EXCESSIVE HORSEPOWER	<ol style="list-style-type: none"> <li>1. Wheel rotating in wrong direction.</li> <li>2. Wheel rubbing on inlet venturi.</li> <li>3. Fan speed higher than design.</li> <li>4. Worn fan bearings.</li> </ol>
EXCESSIVE NOISE	<ol style="list-style-type: none"> <li>1. Wheel or sheaves loose.</li> <li>2. Bearing or drive misalignment.</li> <li>3. Accumulation of material on wheel.</li> <li>4. Worn or corroded wheel.</li> <li>5. Wheel out of balance.</li> <li>6. Wheel hitting housing.</li> <li>7. Bent shaft.</li> <li>8. Bearings need lubrication.</li> <li>9. Loose bearing bolts.</li> <li>10. Loose or worn bearings.</li> <li>11. Mismatched belts.</li> <li>12. Belts too loose or too tight.</li> <li>13. Belts oily or dirty.</li> <li>14. Belts worn.</li> <li>15. Loose fan mounting bolts.</li> <li>16. Rattle of components in high velocity airstream.</li> <li>17. Electrical noise.</li> <li>18. Noise from high velocity air system.</li> <li>19. Vibrating parts not isolated from building.</li> <li>20. Vibrating ductwork.</li> </ol>
EXCESSIVE VIBRATION	<ol style="list-style-type: none"> <li>1. Wheel or sheaves loose on shaft.</li> <li>2. Wheel out of balance.</li> <li>3. Excessive buildup of dirt/dust on wheel.</li> <li>4. Belts too loose or too tight.</li> <li>5. Mismatched belts.</li> <li>6. Bent shaft.</li> <li>7. Bearing or drive misalignment.</li> <li>8. Loose or worn bearings.</li> <li>9. Fan mounting bolts loose.</li> <li>10. Weak mounting base for fan.</li> <li>11. Structures not cross-braced (wall fans).</li> <li>12. Curb not flat and level.</li> </ol>

It is recommended that the users and installers of this shipment familiarize themselves with AMCA Publication #201, "Fans and Systems" and publication #202, "Troubleshooting" which are published by the Air Movement and Control Association (AMCA), 30 West University Drive, Arlington Heights, Illinois 60004. [www.amca.org](http://www.amca.org)

# Maintenance

Installation and maintenance are to be performed only by qualified personnel who are familiar with local codes and regulations and experienced with this type of equipment.

**CAUTION: Sharp edges and screws are a potential injury hazard. Avoid them.**

## WARNING

**Hazardous moving parts.** Unit may contain protected fan motor which may start automatically and cause injury. Allow time for reset. Disconnect power before servicing.

Preventive maintenance is the best way to avoid unnecessary expense and inconvenience. Routine maintenance should cover the following items:

- a. Tighten all setscrews, bolts and wire connections.
- b. Check belt tension and sheaves for wear.
- c. Lubricate fan bearings (see Tables 5 and 6).
- d. Cleaning of unit, wheel and damper (if present).

All motors containing ball bearings are permanently lubricated from the factory. No additional maintenance is required.

1. Before performing any maintenance on the fan, be sure power is turned off and locked in the OFF position at the service entrance.
2. Fans should be carefully checked at least once a year. For critical or rugged applications, a routine check every two or three months is suggested.
3. For repairs within the warranty period, the motor must be taken to the motor manufacturer's authorized service dealer.
4. A periodic motor check should consist of spinning the motor shaft with the power off to be sure the motor turns freely and the bearings run smoothly. The belt on belt driven units should be removed from the motor sheave.
5. When removing or installing a belt, do not force the belt over the sheave. Loosen the motor mount so that the belt can be easily slipped over the sheave.
6. The belt on belt driven units should be removed and carefully checked for glazing, cracks, ply separation or irregular wear. A small irregularity in the contact surface of the belt will result in noisy operation. If any of these defects are apparent, the belt should be replaced. Check the sheaves also for chipping, dents or rough surfaces which could damage the belt.
7. The correct belt tension is important. Too tight of a belt will result in excess bearing pressure on the motor bearings and shaft pillow blocks and may also overload the motor. Too loose of a belt will result in slippage which will quickly "burn" out belts. A belt should feel "live" when thumped, approximately 1/4" belt deflection (3 to 5 lb.) when subject to finger pressure at midpoint between sheaves.

8. The belt alignment should also be checked to be sure the belt is running perpendicularly to the rotating shafts. Fan and motor shafts must be parallel. Improper alignment will result in excessive belt wear.
9. Check sheave setscrews to ensure tightness. Proper keys must be in keyways.
10. Do not readjust fan RPM. If sheaves are replaced, use only sheaves of identical size and type.
11. If unit is to be left idle for an extended period, it is recommended that belts be removed and stored in a cool, dry place to avoid premature belt failure.
12. The standard pillow block bearings on belt driven fans are factory lubricated and are provided with external grease fittings. Lubrication annually is recommended, or more frequently if needed (see Table 5).

It is recommended to add fresh grease at start-up. Use only 2 or 3 shots of a recommended lubricant with a hand gun in most cases (see Table 6). Maximum hand gun rating 40 P.S.I. Rotate bearings during lubrication where good safety practice permits.

**CAUTION:** Greases of different soap bases (lithium, sodium, etc.) may not be compatible when mixed. Prevent such intermixing by completely purging the bearing of old greases.

The most frequent causes of bearing failure are not greasing often enough, using an excessive quantity of grease, or using incompatible greases. Excessive vibration, especially if the bearing is not rotating, will also cause bearings to fail. Bearings must also be protected from water and moisture to avoid internal corrosion.

13. During the first few months of operation it is recommended that the bearing setscrews be checked periodically to ensure that they are tight.
14. The rotating wheel requires particular attention since materials in the air being handled can build up on the blades to cause destructive vibration or weaken the structure of the wheel by corroding and/or eroding the blade metal. Regular inspection and corrective action at intervals determined by the severity of each application are essential to good service life and safety.

Table 5. Suggested Fan Bearing Greasing Intervals

INTERVAL (MONTHS)	TYPE OF SERVICE
12 to 18	Infrequent operation or light duty in clean atmosphere.
6 to 12	8 to 16 hrs./day in clean, relatively dry atmosphere.
3 to 6	12 to 24 hrs./day, heavy duty, or if moisture is present.
1 to 3	Heavy duty in dirty, dusty locations; high ambient temperatures; moisture laden atmosphere; vibration.

Table 6. Grease Manufacturers

MANUFACTURER	GREASE (NLGI #2)
Shell	Alvania RL2
Exxon/Mobil	Ronex MP

## BSI: Belt Driven Centrifugal Inline Fans

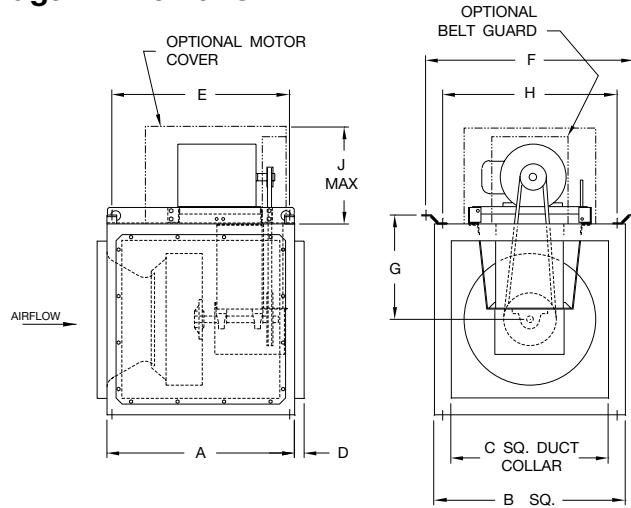

MODEL BSI	A	B	C	D	E	F	G	H	J	DAMPER SIZE	AVG. SHIP WT. (LBS.)	SIDE DISCHARGE SIZE
080A	19.00	15.33	11.88	1.00	16.50	19.50	8.63	13.56	12.00	12.00 x 12.00	93	11.88 x 11.88
090A	19.00	15.33	11.88	1.00	16.50	19.50	8.63	13.56	12.00	12.00 x 12.00	96	11.88 x 11.88
100A	20.50	17.81	13.88	1.00	19.00	21.06	10.38	16.00	12.00	14.00 x 14.00	106	13.88 x 13.88
120A/120AHP	21.50	19.38	15.88	1.00	20.00	22.06	11.13	17.00	12.00	16.00 x 16.00	127	15.88 x 15.88
135A/135AHP	23.00	21.56	17.88	1.00	21.50	24.25	12.19	19.16	12.75	18.00 x 18.00	132	17.88 x 17.88
150A/150AHP	24.00	23.82	19.88	1.00	22.50	26.38	13.29	21.31	12.75	20.00 x 20.00	157	19.88 x 19.88
165A/165AHP	26.00	26.50	22.88	1.00	24.50	29.06	14.64	24.00	14.56	23.00 x 23.00	167	22.88 x 22.88
180A/180AHP	28.50	29.00	23.88	1.50	27.00	31.56	15.89	26.50	16.25	24.00 x 24.00	193	23.88 x 23.88
210A/210AHP	32.00	32.34	27.88	1.50	30.50	35.06	17.54	30.00	16.25	28.00 x 28.00	223	27.88 x 27.88
225A/225AHP	34.00	34.00	29.88	1.50	32.50	36.89	18.45	31.81	18.50	30.00 x 30.00	287	25.88 x 28.88
245A/245AHP	36.50	37.50	32.88	1.50	35.00	40.38	20.20	35.31	18.50	33.00 x 33.00	352	27.88 x 31.88
270A/270AHP	39.00	40.13	35.88	1.50	37.50	43.00	21.45	37.88	18.50	36.00 x 36.00	394	29.88 x 33.88
300A/300AHP	41.50	44.13	39.88	1.50	39.50	46.95	23.45	41.88	20.00	40.00 x 40.00	442	29.88 x 37.88
330A/330AHP	45.50	48.81	43.88	1.50	43.50	51.63	25.78	46.56	20.00	44.00 x 44.00	554	31.88 x 39.88
365A/365AHP	48.50	50.13	45.88	1.50	46.50	52.94	26.44	47.88	20.00	46.00 x 46.00	665	32.88 x 41.88
402A/402AHP	52.00	55.25	51.88	1.50	50.00	58.19	29.09	53.13	20.00	52.00 x 52.00	743	34.88 x 46.88

DIMENSIONS ARE NOT TO BE USED FOR CONSTRUCTION.

## DSI: Direct Drive Centrifugal Inline Fans

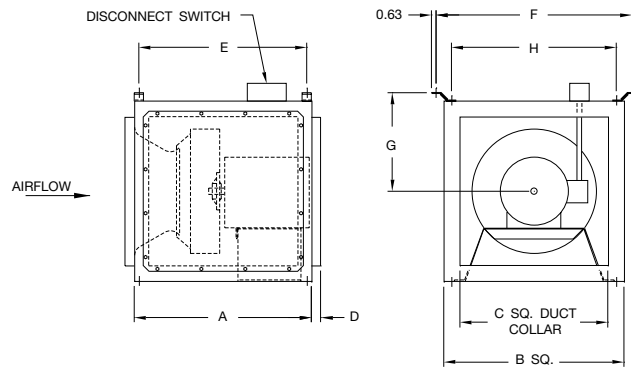

MODEL DSI	A	B	C	D	E	F	G	H	DAMPER SIZE	AVG. SHIP WT. (LBS.)	SIDE DISCHARGE SIZE
080A	19.00	15.33	11.88	1.00	16.50	19.50	8.63	13.56	12.00 x 12.00	93	11.88 x 11.88
090A	19.00	15.33	11.88	1.00	16.50	19.50	8.63	13.56	12.00 x 12.00	96	11.88 x 11.88
100A	20.50	17.81	13.88	1.00	19.00	21.06	10.38	16.00	14.00 x 14.00	106	13.88 x 13.88
120A	21.50	19.38	15.88	1.00	20.00	22.06	11.13	17.00	16.00 x 16.00	127	15.88 x 15.88
135A/135AN	23.00	21.56	17.88	1.00	21.50	24.25	12.19	19.16	18.00 x 18.00	132	17.88 x 17.88
150A/150AN	24.00	23.82	19.88	1.00	22.50	26.38	13.29	21.31	20.00 x 20.00	157	19.88 x 19.88
165A/165AN	26.00	26.50	22.88	1.00	24.50	29.06	14.64	24.00	23.00 x 23.00	167	22.88 x 22.88

DIMENSIONS ARE NOT TO BE USED FOR CONSTRUCTION.

# Mounting Brackets

BSI and DSI square inline fans can be mounted in any position: horizontal, vertical or angular. They can be hung from above or mounted on the floor. Typical dimensions (E and F) for the mounting brackets that are supplied with these units are shown on page 8. The

$\frac{9}{16}$ " holes in these brackets can readily be used for installing the units. To obtain optimum isolation, the BSI unit should be installed with the motor above or below the fan body.

## Overhead Mounting

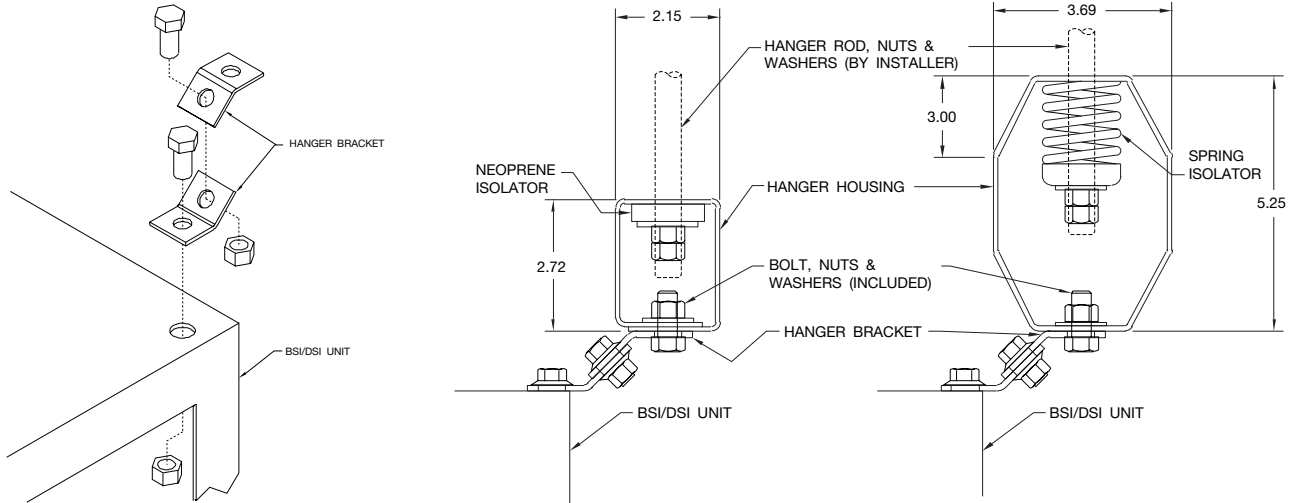

## Floor Mounting

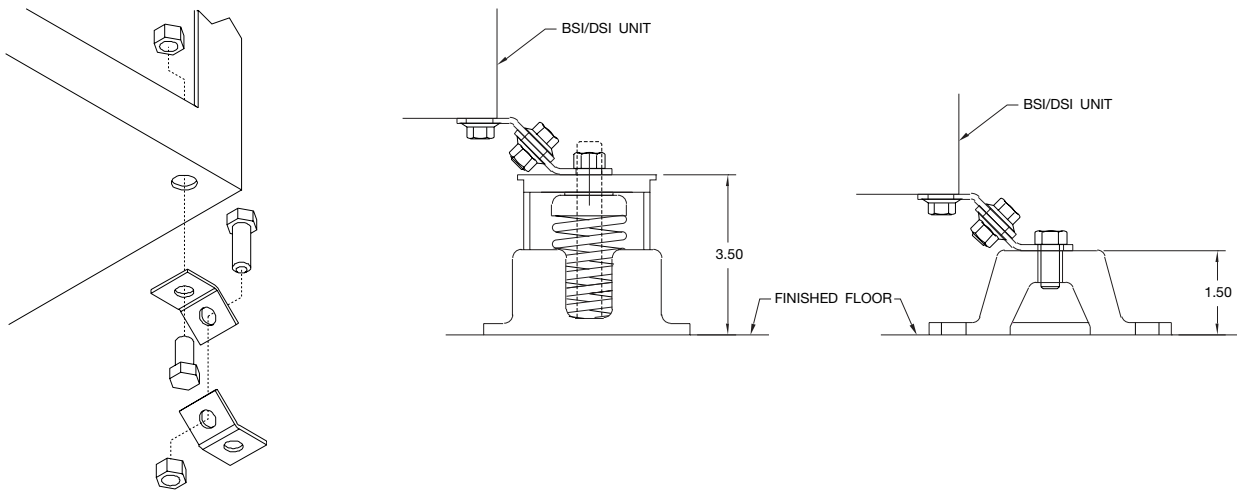

# Side Discharge Option

Side discharge kits (including panels, mounting collars, and necessary hardware) are available to provide 1-way,

2-way, or 3-way discharges. **Note:** Panel opposite motor (on belted BSI) cannot be used for discharge.

## Configurations

Option	Figure	Configuration
Standard	A	Rear
1-Way	B	Left
	C	Right
2-Way	D	Left and Right
	E	Left and Rear
	F	Right and Rear
3-Way	G	Left, Right and Rear

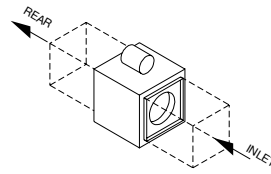

Fig. A

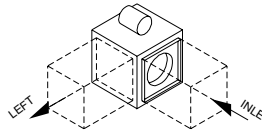

FIG. B

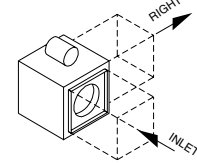

FIG. C

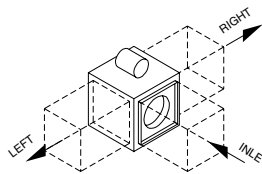

FIG. D

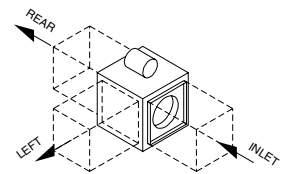

FIG. E

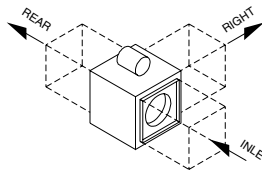

FIG. F

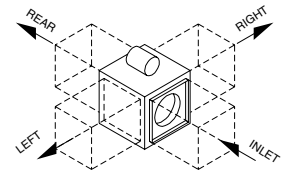
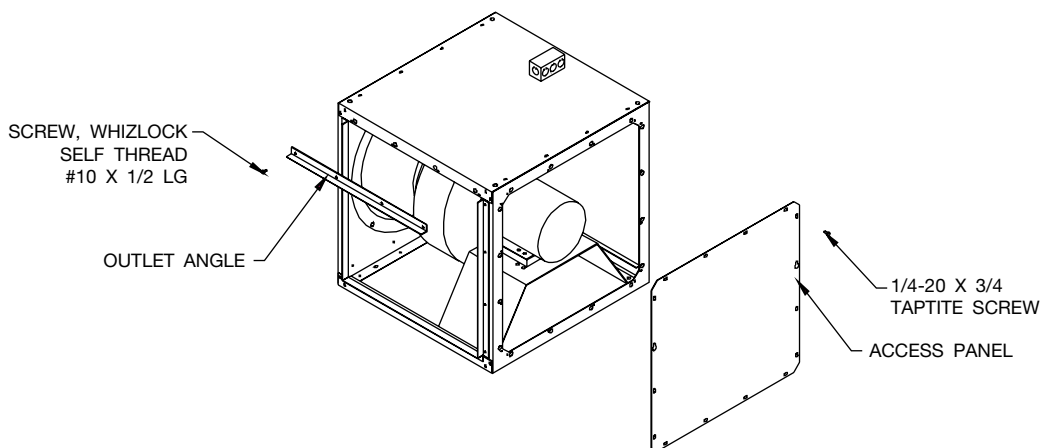

FIG. G

## Duct Openings

Model BSI	Model DSI	Left and Right Discharge			Rear Discharge/Inlet		
		Duct Collar		Duct Size Required	Duct Collar		Duct Size Required
		Width	Height		Width	Height	
080	080	11.88	11.88	12 x 12	11.88	11.88	12 x 12
090	090	11.88	11.88	12 x 12	11.88	11.88	12 x 12
100	100	13.88	13.88	14 x 14	13.88	13.88	14 x 14
120	120	15.88	15.88	16 x 16	15.88	15.88	16 x 16
135	135	17.88	17.88	18 x 18	17.88	17.88	18 x 18
150	150	19.88	19.88	20 x 20	19.88	19.88	20 x 20
165	165	22.88	22.88	23 x 23	22.88	22.88	23 x 23
180	—	23.88	23.88	24 x 24	23.88	23.88	24 x 24
210	—	27.88	27.88	28 x 28	27.88	27.88	28 x 28
225	—	25.88	28.88	26 x 29	29.88	29.88	30 x 30
245	—	27.88	31.88	28 x 32	32.88	32.88	33 x 33
270	—	29.88	33.88	30 x 34	35.88	35.88	36 x 36
300	—	29.88	37.88	30 x 38	39.88	39.88	40 x 40
330	—	31.88	39.88	32 x 40	43.88	43.88	44 x 44
365	—	32.88	41.88	33 x 42	45.88	45.88	46 x 46
402	—	34.88	46.88	35 x 47	51.88	51.88	52 x 52

## Side Discharge Instructions



### NOTES:

1. Remove outlet angles from fan discharge.
2. Remove access panel from side required to be discharge.
3. Mount outlet angles on new discharge.
4. Mount access panel on back of fan (previous outlet).

## Limitation of Warranties and Claims

Seller warrants to the original purchaser that the goods sold hereunder shall be free from defects in workmanship and material under normal use and service (except in those cases where the materials are supplied by the buyer) for a period of one year from the date of original installation or eighteen (18) months from the date of shipment, whichever occurs first. The liability of seller under this warranty is limited to replacing, repairing, or issuing credit (at cost, F.O.B. factory and at seller's discretion) for any part or parts which are returned by buyer during such period provided that:

- a. seller is notified in writing within ten (10) days following discovery of such defects by buyer, or within ten (10) days after such defects should reasonably have been discovered, whichever is less;
- b. the defective unit is returned to seller, transportation charges prepaid by buyer.
- c. payment in full has been received by seller for said products; and
- d. seller's examination of such unit shall disclose to its satisfaction that such defects have not been caused by misuse, neglect, improper installation, repair, alteration, act of God, or accident.

No warranty made hereunder shall extend to any seller product whose serial number is altered, effaced or removed. Seller makes no warranty, express or implied, with respect to motors, switches, controls, or other components of seller's product, where such components are warranted separately by their respective manufacturers. THIS WARRANTY IS EXPRESSLY IN LIEU OF ALL OTHER WARRANTIES, EXPRESS OR IMPLIED, WHETHER STATUTORY OR OTHERWISE, INCLUDING ANY IMPLIED WARRANTY OF MERCHANTABILITY OR FITNESS FOR A PARTICULAR PURPOSE. In no event shall seller be liable to buyer for indirect, incidental collateral, or consequential damages of any kind. (BUYER'S FAILURE TO PAY THE FULL AMOUNT DUE WITHIN SIXTY (60) DAYS OF INVOICE SHALL OPERATE TO RELEASE SELLER FROM ANY AND ALL LIABILITY OR OBLIGATION ARISING PURSUANT TO ANY WARRANTY, EXPRESS OR IMPLIED, WHETHER STATUTORY OR OTHERWISE, INCLUDING ANY IMPLIED WARRANTY OR MERCHANTABILITY OR FITNESS FOR A PARTICULAR PURPOSE, MADE IN CONNECTION WITH ANY CONTRACT FORMED HEREUNDER. BUYER AGREES THAT SUCH FAILURE TO PAY SHALL CONSTITUTE A VOLUNTARY WAIVER OF ANY AND ALL SUCH WARRANTIES ARISING PURSUANT TO SUCH CONTACT.)



# Twin City Fan & Blower

*A Twin City Fan Company*

5959 Trenton Lane · Minneapolis, MN 55442-3237  
Phone (763) 551-7600 · Fax (763) 551-7601 · [www.tcf.com](http://www.tcf.com)

4MPP01/10

